

KAPTECH

HYGIENIC HOSE ASSEMBLIES



FS 28046

GUYSON

KAPTECH

HYGIENIC HOSE ASSEMBLIES

FOR THE FOOD, DAIRY, BREWING & PHARMACEUTICAL INDUSTRIES

Guyson expertise in hygienic hose assemblies is based on many years experience in supplying hoses for a wide range of industry applications, handling all kinds of food, drink, dairy and pharmaceutical products, process fluids, gases, CIP liquors, etc. All Kaptech hygienic hoses are manufactured from FDA-approved materials.

Kaptech End Fittings

Careful design and manufacture of Kaptech end fittings for hygienic applications ensures complete security of attachment, maximum smooth flow path and suitability for successful CIP.

All hose assemblies are fully leak-tested before despatch.

Test certificates and/or certificates of conformity can be supplied if required.

End fittings in undamaged condition can be re-used for repair or renewal of hose assemblies to give useful cost savings in some cases.

THE KAPTECH ASSEMBLY METHOD

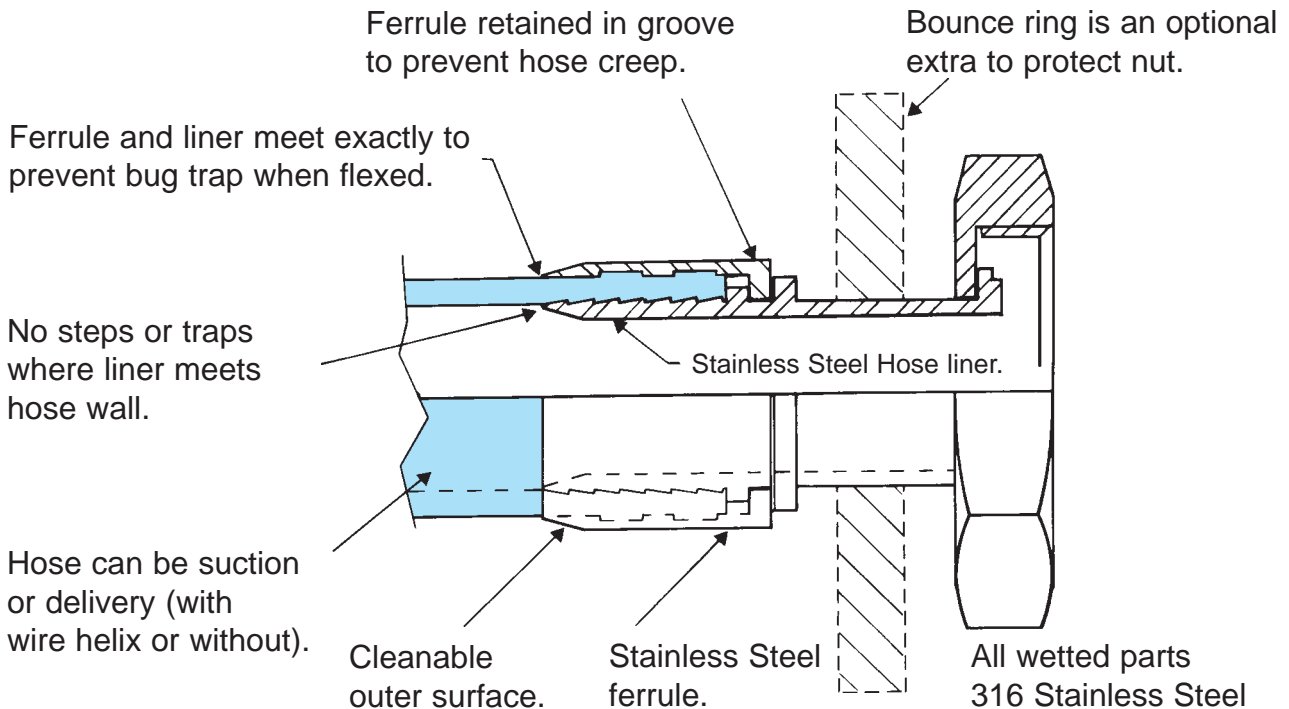

Shown below are the weaknesses of other assembly methods not recommended by Guyson

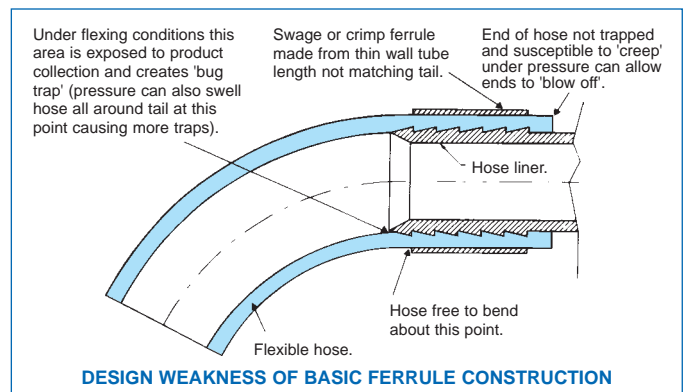
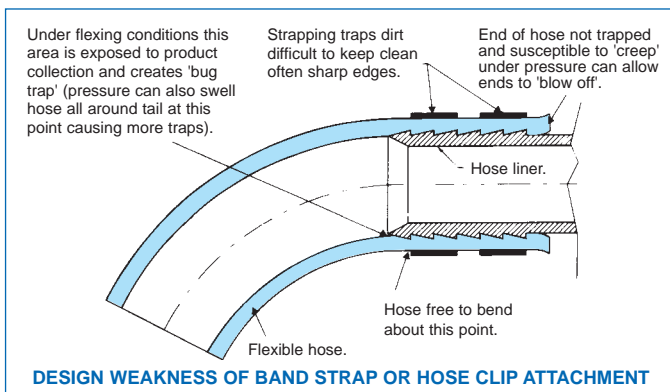

GUYSON INTERNATIONAL LIMITED HOSE & COUPLINGS DIVISION

Southview Business Park, Guiseley, Leeds LS20 9PR Tel: 01943 870044 Fax: 01943 870066

Email: leeds@guyson.co.uk Web: www.guyson.co.uk

KAPTECH

HYGIENIC HOSE ASSEMBLIES

Kaptech hygienic hoses shown below are widely used and well proven in all kinds of hygienic fluids applications, offering ease of handling, durability and CIP suitability. Other more specialised Kaptech hoses are available for specific applications.

FDA-approved rubber hoses

Kaptech Premium Food and Brewers hose

The highest quality hose for tough applications where high strength and durability are needed. Will handle pressures up to 17bar and suction down to 70% full vacuum. Recovers shape after vehicle run-over.

Kaptech Ultraflex Food and Brewers hose

The light weight and high flexibility of Kaptech Ultraflex hose result in exceptional ease of handling, which is much appreciated by operators. Suitable for up to 10bar operation.

FDA-approved Silicone hoses

Kaptech silicone hoses offer exceptionally high standards of operational cleanliness, coupled with excellent flexibility, giving especial suitability for pharmaceutical and biomedical applications.

Kaptech Silicone Delivery hose

A range of extruded hose manufactured with a variety of reinforcing materials to provide graduated strengths and temperature ranges.

Kaptech Silicone Suction and Delivery hose

Mandrel-built hoses with multiple reinforcement layers and helices to provide exceptional suction and pressure capabilities. They offer easy cleaning characteristics internally and externally, by both manual and automatic means.

Kaptech Silicone Specials

Guyson offers custom-design and production of bellows, U-bends and other special products in FDA-approved silicone, as well as some standard products.

Kaptech FDA-approved Chemical hoses

Specialised, kink-resistant PTFE and UHMWPE-lined for a whole range of food and pharmaceutical industry applications where exceptional chemical resistance is needed.

Kaptech non-glass Sight-glasses

Manufactured in TEFLON/FEP to give non-breakable sight-glasses which can be built into Kaptech hose assemblies or supplied separately for installation in customers' pipework.

End Fittings for Hygienic Service

Guyson offer a wide range of hygienic styles of end fitting. Shown below are the more regularly specified types; all can be hygienically and permanently connected to any of the range of hoses listed in this brochure.

All Kaptech hygienic fittings are produced in 316 Stainless Steel (with 304SS nuts/ferrules), and are available in the wide range of sizes shown below.

As an optional extra Guyson can also provide rubber bounce rings to protect fittings and floors from unnecessary damage.



RJT

Manufactured to BS 1864. Used for ease of dismantling for washing and sterilising. Sizes 1" to 4".



IDF/ISS

International Dairy Federation standard (also known as International Sanitary Standard). With its

flush, crevice-free joint it is highly suitable for CIP.

Sizes 1" to 4" (can be supplied with round nut).



DIN 11851

Manufactured mostly to German and European standards with round slotted nuts. Sizes 1" to 4".



SMS

This Swedish standard has a slotted round nut. Sizes 1" to 4".



Tri-Clamp

Made to "Tri-Clover" design and American 3A standards. The self-aligning union has a smooth crevice-

free bore. Various seals. Sizes 1/2" to 4" (also available in Mini-Tri-Clover).

Other Types available:

316 SS Camlock fittings.

Flanged connections.

Special fittings to suit customer requirements.



GUYSON INTERNATIONAL LIMITED HOSE & COUPLINGS DIVISION

Southview Business Park, Guiseley, Leeds LS20 9PR Tel: 01943 870044 Fax: 01943 870066

Email: leeds@guyson.co.uk Web: www.guyson.co.uk

KAPTECH

ULTRAFLEX FOOD & BREWERS HOSE

The light weight and high flexibility of Kaptech Ultraflex gives exceptional ease of handling in food and brewing industry applications. As well as handling fatty and non-fatty foods (eg chocolate, milk, vegetable oils) Ultraflex has also found wide approval for beer and beverage transfer applications.

Ultraflex has a smooth inner white liner in a nitrile/PVC blend which meets and exceeds FDA specifications for avoidance of transference of taste or odour. The EPDM outer cover material is formulated to resist aggressive working conditions such as abrasion and environmental attack.

Its structure of synthetic fabric plies and embedded high tensile wire helix gives exceptional vacuum and pressure performance. The convoluted outer surface optimizes flexibility and ease of handling.

Most sizes are available with red, blue, green or yellow outer covers offering visual identification of different product lines.



FS 28046



For capabilities and general technical data, see overleaf

KAPTECH

ULTRAFLEX FOOD & BREWERS HOSE



Benefits

- FDA to: CFR21-177-2600 & 3-A compliant
- EC1935/2004 & EC2023/2006 compliant
- ADI free & non-phthalate
- Full vacuum capability
- Extra-flexible - tight bend radius
- Light weight - Suitable for CIP
- Working pressures up to 10 bar
- Available in continuous lengths up to 40 metres
- White non-tainting liner, cover options allow colour coding of product lines
- Different colours can be dedicated to individual departments within a site

Nominal Bore		Outside Dia. mm (approx.)	Max. Working Pressure	Weight kg/m (approx.)	Min. Bend Radius mm (approx.)
Inch	mm				
1"	25	37.3	10 bar	0.60	85
1½"	38	51.3	10 bar	1.07	105
2"	51	63.6	10 bar	1.70	120
2½"	63	76.3	10 bar	2.43	130
3"	76	91.3	10 bar	2.94	150
4"	102	116.6	10 bar	4.00	230

Pressure ratings shown are valid for Group 2 fluids only [per Pressure Equipment Directive 97/23/EC, Art.9 (2)]. Consult Guyson Technical Department for Group 1 (dangerous) fluids ratings.

Working pressure of hose is based on a minimum safety factor of 4:1

Fittings

Hoses can be delivered as complete hygienic assemblies using either customer-specified or standard fittings such as:-

- RJT to BS 1864
- IDF (ISS) International Dairy Federation
- DIN 11851 German and European standards
- SMS Swedish standard
- Tri-clamp
- Hygienic Camlock coupling



To comply with FDA requirements, all hose liners are manufactured from 316 stainless steel.

Hose ferrules and nuts (where applicable) are manufactured from 304 stainless steel.



GUYSON INTERNATIONAL LIMITED **HOSE & COUPLINGS DIVISION**
 Southview Business Park, Guiseley, Leeds LS20 9PR Tel: 01943 870044 Fax: 01943 870066
 e-mail: leeds@guyson.co.uk web: www.guyson.co.uk



FS 28046

NOTE: All technical information shown correct at time of print and may be subject to change without notice. Products supplied may differ in appearance and colour to items shown. For specific applications and working conditions, please consult Guyson Technical Sales Department.

UF0117

KAPTECH

PREMIUM FOOD & BREWERS HOSE

KAPTECH PREMIUM HOSE

is an exceptionally robust hose designed to give powerful performance and long life in food and brewing industry applications. Pressure and suction performance are achieved by its wire-free construction employing special multiple synthetic fabric plies. The EPDM outer cover material is formulated to resist aggressive working conditions such as abrasion, compression and environmental attack.



KAPTECH PREMIUM FOOD HOSE

has an inner white liner in a nitrile/PVC blend which meets and exceeds FDA specifications for avoidance of transference of taste or odour and enables both fatty and non-fatty foods to be handled. It is distinctively colour-coded in blue with a bold yellow tape branded 'Kaptech Premium Food Quality Hose'.



KAPTECH PREMIUM BREWERS HOSE

is designed specifically for liquids transfer in the brewing and related industries. It is manufactured with a white inner lining of chlorobutyl rubber complying with FDA requirements for complete elimination of taste and odour transfer. It is particularly suitable for CIP systems. It is colour coded in red with a bold white tape branded 'Kaptech Premium Brewers Hose' or 'Brewline Hose' depending on availability.



FS 28046



For capabilities and general technical data, see overleaf

KAPTECH

PREMIUM FOOD & BREWERS HOSE



Benefits

- FDA-approved non-tainting liner
- Handles suction up to 70% of full vacuum
- Operates at pressures up to 17 bar
- Excellent resistance to abrasion and damage
- Recovers shape after vehicle run-over
- Suitable for CIP
- Available in continuous lengths up to 60 metres

Nominal Bore		Outside Dia. mm	Working Pressure	Approximate Weight	
Inch	mm			kg/m	lb/ft
1"	25	42.6	17 bar	1.19	0.80
1½"	38	56.5	17 bar	1.71	1.15
2"	51	72.9	17 bar	2.62	1.76
2½"	63	87.0	17 bar	3.70	2.48
3"	76	104.9	17 bar	4.87	3.27
4"	102	134.5	17 bar	7.53	5.05

Kaptech Premium Brewers / Brewline Hose is supplied subject to availability / special order.

Pressure ratings shown are valid for Group 2 fluids only [per Pressure Equipment Directive 97/23/EC, Art.9 (2)]. Consult Guyson Technical Department for Group 1 (dangerous) fluids ratings.

Working pressures are based on a minimum safety factor of 4: 1

Fittings

Hoses can be delivered as complete hygienic assemblies using either customer-specified or standard fittings such as:-

- RJT to BS 1864
- IDF (ISS) International Dairy Federation
- DIN 11851 German and European standards
- SMS Swedish standard
- Tri-clamp
- Hygienic Camlock coupling

To comply with FDA requirements, all hose liners are manufactured from 316 stainless steel. Hose ferrules and nuts (where applicable) are manufactured from 304 stainless steel.

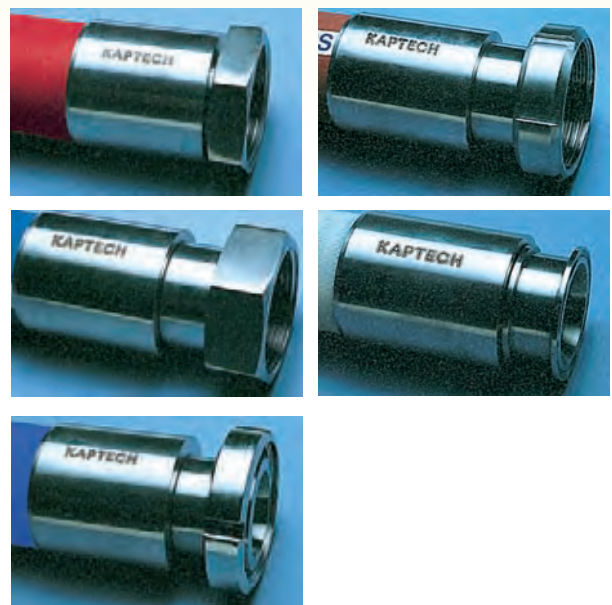

GUYSON INTERNATIONAL LIMITED

Southview Business Park, Guiseley, Leeds LS20 9PR Tel: 01943 870044 Fax: 01943 870066
e-mail: leeds@guyson.co.uk web: www.guyson.co.uk

HOSE & COUPLINGS DIVISION



KAPTECH

S I L I C O N E H O S E

FOR THE FOOD, BREWING & PHARMACEUTICAL INDUSTRIES

Kaptech silicone hose assemblies offer exceptionally high standards of operational cleanliness, with excellent flexibility and high temperature performance.



KAPTECH ST60 & ST50 PLATINUM-CURED SILICONE

a tough suction and delivery hose with good flexibility and high resistance to kinking in lengths up to 4 metres, reinforced with embedded polyester braids and a stainless steel or Hastelloy spring wire helix.

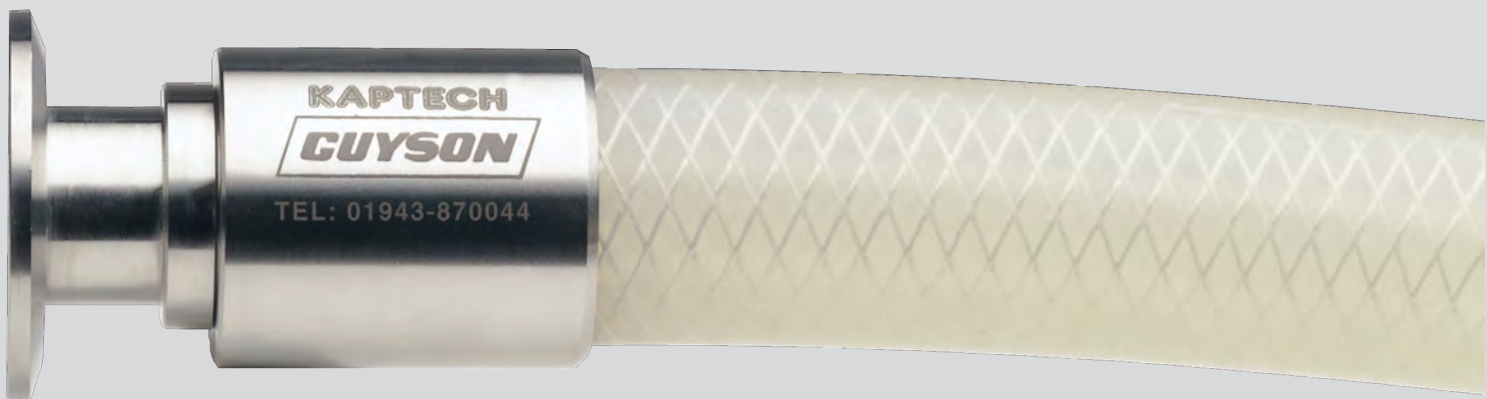

KAPTECH SX10 SILICONE HOSE

a general purpose delivery hose available in lengths up to 20 metres, reinforced with embedded glass-fibre braids.



FS 28046



For capabilities and general technical data, see overleaf

KAPTECH

S I L I C O N E H O S E

Kaptech ST60 & ST50 Silicone Hose

- Complies with FDA 21CFR177.2600 & USP Class VI
- Suction and delivery capability from full vacuum to 10 bar (up to 2" ST60), 2.1/2" - 7 bar, 3" - 6 bar and 4" - 5 bar (ST50)
- Working temperatures up to 180°C, dependent on specification & application details
- High kink-resistance
- Smooth translucent bore and cover
- Available in sizes 1/2" - 4"
- Platinum-cured

	Nominal Bore	Outside Dia. (mm)	Working Pressure (bar)	Min Bend Radius (mm)
ST60	1/2"	25	10	45
	3/4"	32	10	65
	1"	38	10	136
	1 1/4"	44	10	178
	1 1/2"	51	10	215
	2"	63	10	440
ST50	2 1/2"	73	7	220
	3"	86	6	250
	4"	111	5	460

Note: for use at 100°C and above, the working pressure is reduced. For specific applications, consult Guyson Technical Department.

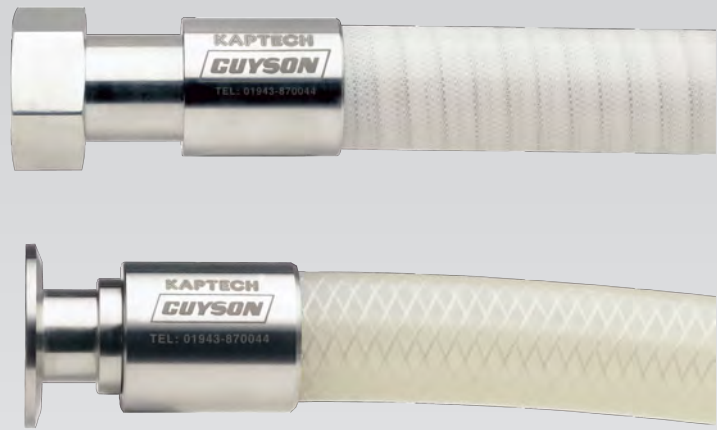
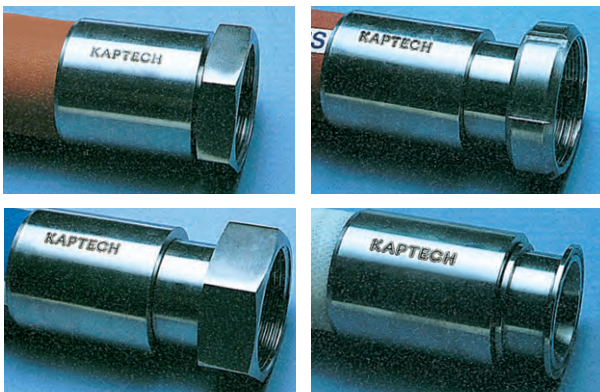

Kaptech SX10 Silicone Hose

- Complies with FDA 21CFR177.2600
- Suitable for delivery pressures up to 12 bar according to size (see table)
- Working temperatures up to 220°C
- Available in lengths up to 20 metres
- Smooth translucent bore and cover
- Available in sizes 1/4" - 1"
- Peroxide-cured, platinum-cured version available to order.

Nominal Bore	Outside Dia. (mm)	Working Pressure (bar)
1/4"	12	12
3/8"	17	9
1/2"	20	9
3/4"	30	7
1"	37	5

Fittings

Hoses can be delivered as complete hygienic assemblies using either customer-specified or standard fittings such as:-

- RJT to BS 1864
- IDF (ISS) International Dairy Federation
- DIN 11851 German and European standards
- SMS Swedish standard
- Tri-clamp
- Hygienic Camlock coupling

All fittings are produced in 316 stainless steel (with 304SS nuts) to comply with FDA requirements



GUYSON INTERNATIONAL LIMITED

Southview Business Park, Guiseley, Leeds LS20 9PR Tel: 01943 870044 Fax: 01943 870066
e-mail: leeds@guyson.co.uk web: www.guyson.co.uk

HOSE & COUPLINGS DIVISION



KAPTECH

FLEXIBLE SMOOTH BORE PTFE PROCESS HOSE ASSEMBLIES

PTFE 7000 BIOFLEX ULTRA

- **Unique combination of smooth-bore and high flexibility.**
- **New improved kink resistance.**
- **Excellent chemical resistance**
Inert to all but a handful of uncommon chemicals.
- **Easy to clean**
The non-stick nature of the PTFE tube helps prevent product adhering to the tube wall.
- **Hygienic**
Manufactured from FDA-approved PTFE.
- **Excellent flow**
Flow rates are approximately double those of conventional convoluted hose, dependant on application.



- **Heat-resistant**
Usable up to 260°C, dependent on specification and application details.
- **Vacuum resistant**
Usable with full vacuum dependent on specification and application details.
- **Sizes:** 1/2" up to 2" nb.
- **Various tube, braid and cover options.**
- **Wide range of end fittings available.**

CUYSON

For capabilities and general technical data, see overleaf



FS 28046

KAPTECH

PTFE 7000 BIOFLEX ULTRA FLEXIBLE SMOOTH BORE PTFE HOSE ASSEMBLIES

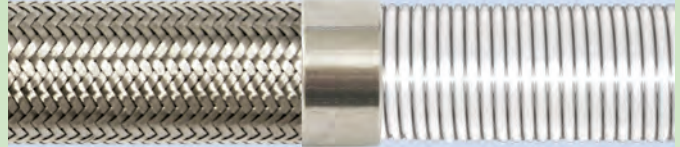

Kaptech PTFE 7000 Bioflex Ultra flexible PTFE hose offers a unique solution to the need for a smooth bore hose with the flexibility of a convoluted hose.

The Bioflex Ultra PTFE tube design incorporates integral external rib sections which along with a high tensile 316 stainless steel wire helically wound in to the root of the convolutions, support the tube against kinking, vacuum and pressure. Highly compressed web sections give a smooth inner surface with excellent flexibility. Compared to conventional convoluted PTFE hose, Bioflex Ultra gives much improved performance; at least double the flow rate, excellent gas permeation resistance, and superior flexing cycle life.

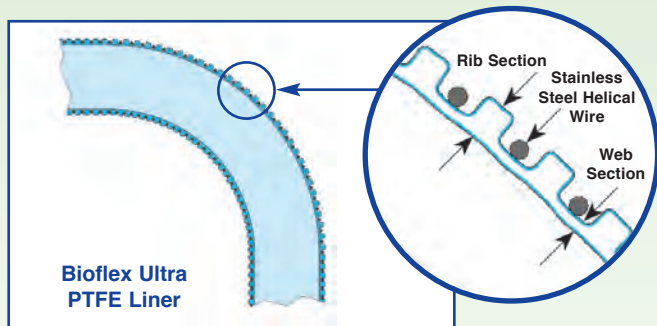

Tube Options:

General purpose (GP): this is the general purpose natural translucent PTFE tube option.

Anti-static (AS): this is a black anti-static PTFE tube option. Please consult Guyson Technical department when selecting this option.

Tube only (TO): this is an unbraided tube-only option available where a translucent, low pressure or light weight hose is required.



Braid Options:

Stainless steel braid (SS): the stainless steel braid option using high tensile 316 stainless steel wire can be selected, to give maximum hose pressure capabilities.

Polymer braid (PB): a light weight polypropylene braid option is available which may be preferred in applications involving frequent handling of the hose.

Other Kaptech PTFE hoses available include: PTFE 1000 smooth bore, PTFE 3000 convoluted (industrial applications) PTFE 4000 Hyperline FX smooth bore (industrial applications) and PTFE 5000 Corroflon convoluted (process applications).



GUYSON INTERNATIONAL LIMITED

Southview Business Park, Guiseley, Leeds LS20 9PR Tel: 01943 870044 Fax: 01943 870066
email: leeds@guyson.co.uk web: www.guyson.co.uk

HOSE & COUPLINGS DIVISION



FS 28046

NOTE: All technical information shown correct at time of print and may be subject to change without notice. For specific applications, please consult Guyson Technical Department.

Cover Options:

Blue EPDM rubber cover (RC): this option can be selected where additional protection from rough treatment or severe external abrasion is required. This option may also be used where smoothness or easy cleaning of the outside of the hose is required.

Platinum cured silicone rubber cover (SI): this option may be used where elevated temperatures are present and has the added benefit of being semi-transparent allowing visual monitoring of the braid.

Other rubber covers and external protection systems are available please consult Guyson Technical Department for details.

End Fittings:

All hoses assemblies can be fitted with most conventional types of end fittings. A full range of hygienic type end fittings such as RJT, IDF, DIN, SMS and Tri-clamp (lined or non-lined) are available. Most threaded connections including BSP and NPT are available, as are most styles of swivel flanges in various materials.

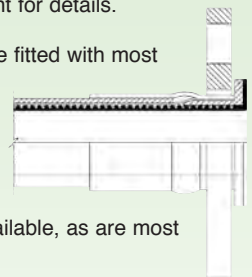

Stainless Steel Braided (SS)

Bore Size	Minimum Bend Radius	Maximum Working Pressure	Weight Per Metre	Maximum Cont. Length
Inches	mm	bar	kg	m
1/2	38	70	0.290	30
3/4	50	60	0.400	30
1	70	50	0.630	30
1 1/4	100	45	0.850	30
1 1/2	140	40	1.100	30
2	200	30	1.900	30

Pressure ratings shown are valid for Group 2 fluids only [per Pressure Equipment Directive 97/23/EC, Art.9 (2)]. Consult Guyson Technical Department for Group 1 (dangerous) fluids ratings.

Pressure range.

Pressures shown above are for PTFE 7000 Bioflex Ultra with stainless steel braid option (SS) at ambient temperature. For versions with other braid or tube only (TO) options, please consult Guyson Technical Department.

Max working pressures are based on a minimum 4:1 factor of safety on the burst pressures.

NOTE: The maximum working pressure of a hose assembly is limited to the lowest of the maximum working pressures of either of the two end fittings or the hose itself.

Temperature range.

Usable from -73°C to +260°C dependent on specification and application details. Please consult Guyson Technical Department.

KAPTECH

CONVOLUTED PTFE PROCESS HOSE ASSEMBLIES

- **Excellent flexibility**
Convoluted tube allows tight, kink-free bends and ease of handling.
- **Self-cleaning**
The non-stick nature of the tube and the low angle of the convolutions ensure excellent cleanability.
- **Hygienic**
Manufactured from FDA-approved PTFE.
- **Heat-resistant**
Usable up to 260°C, dependent on specification and application details.
- **Excellent steam resistance**
Longer service life than rubber steam hoses.
- **Durable**
Tough outer braid protects against abrasion and damage.
- **Vacuum resistant**
Usable with full vacuum (sizes up to 2" nb, max 130°C) dependent on specification and application details.
- **Sizes:** 1/2" up to 6" nb.
- **Wide range of end fittings:** BSP, NPT, flanges, hygienic type, etc.

PTFE 5000 CORROFLON

- **Excellent chemical resistance**
Inert to all but a handful of uncommon chemicals.
- **Low flow-resistance**
The smooth low-friction tube and low angle of the convolutions give good flow capacity.

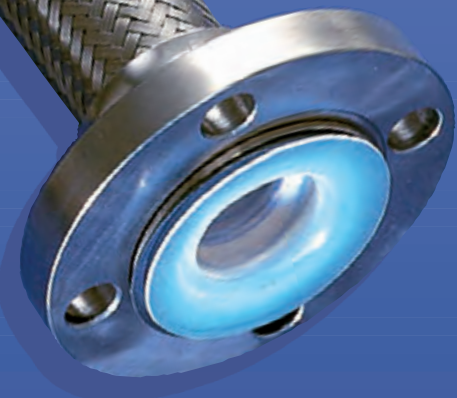
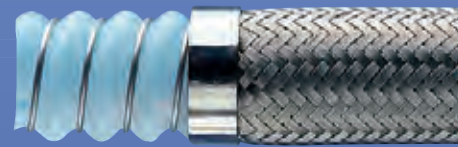

FS 28046



HOSE & COUPLINGS DIVISION

For capabilities and general technical data, see overleaf

KAPTECH

PTFE 5000 CORROFLON - CONVOLUTED PTFE PROCESS HOSE ASSEMBLIES

Kaptech PTFE 5000 Corroflon convoluted PTFE hose is widely regarded as the optimum choice for process applications, especially in the pharmaceuticals, food and chemicals industries.

Anti-static: In addition to the standard translucent tube, Kaptech PTFE 5000 Corroflon hose is available with an anti-static black PTFE tube (AS). This is designed for applications where fluids with a high electrical resistance such as solvents and fuels are passed through the hose and allows the dissipation of any static charge in accordance with BS2050: 1978.

Tube Only: An unbraided tube-only option (TO) is also available for applications where a translucent, low-pressure hose is required. Other specialist PTFE tubes are available to special order.

Braid Options: Kaptech PTFE 5000 Corroflon PTFE hose is provided as standard with an external stainless steel braid. It is also available with a polymer braid (PB) manufactured from a polypropylene yarn which provides a lightweight braid with excellent chemical resistance and comfortable handling characteristics. Other specialist braids and covers are available to special order.

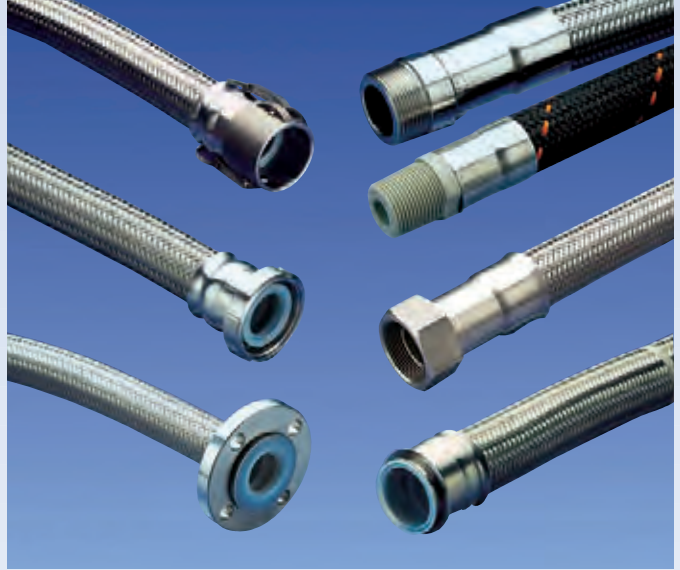

End Fittings.

Kaptech PTFE 5000 Corroflon hose assemblies can be fitted with all conventional types of end fittings. Standard types include BSP and NPT threaded fittings in zinc-plated mild steel and 316SS; swivel flanges in 304, 316SS and polypropylene are also options. A full range of hygienic type end fittings such as RJT, IDF and Tri-clamp are available, and these can be PTFE-lined where the sealing technique allows. Cuffed ends suitable for customers to attach their own fittings are available to special order.

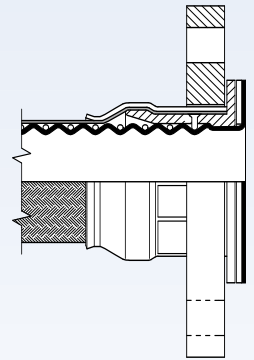

Pressure range.

Pressure ratings shown are for PTFE 5000-SS (stainless braid) at ambient temperature. For versions with other braid or tube-only (TO) options, please contact Guyson Technical Department.

Max working pressures are based on a 4:1 factor of safety on the burst pressures.

Temperature range.

Usable from -73°C to +260°C dependent on specification and application details, please consult Guyson Technical Department.

Stainless Steel Braided				
Bore Size	Minimum Bend Radius	Maximum Working Pressure	Weight Per Metre	Maximum Cont. Length
Inches	mm	bar	kg	m
1/2	38	41	0.330	28
3/4	51	35	0.450	30
1	70	31	0.700	40
1 1/4	82	27	0.820	30
1 1/2	100	23	1.500	25
2	140	20	2.100	18
2 1/2	178	16	2.580	13
3	230	14	3.290	10
4	300	10	5.050	5
6	600	5	10.000	4

Pressure ratings shown are valid for Group 2 fluids only [per Pressure Equipment Directive 97/23/EC, Art.9 (2)]. Consult Guyson Technical Department for Group 1 (dangerous) fluids ratings.

Other Kaptech PTFE hoses available include: PTFE 1000 smooth bore, PTFE 3000 convoluted (industrial applications), PTFE 4000 Hyperline smooth bore (industrial applications) and Bioflex smooth bore (process applications). PTFE moulded & 'V' type bellows are also available to special order.



GUYSON INTERNATIONAL LIMITED **HOSE & COUPLINGS DIVISION**
Southview Business Park, Guiseley, Leeds LS20 9PR Tel: 01943 870044 Fax: 01943 870066
e-mail: leeds@guyson.co.uk web: www.guyson.co.uk



KAPTECH

FLEXIBLE SMOOTH BORE PTFE INDUSTRIAL HOSE ASSEMBLIES

PTFE 4000 HYPERLINE FX

- **Self-cleaning**
The non-stick nature of the PTFE tube prevents product adhering to the tube wall.
- **Low flow resistance**
Smooth bore gives superior flow rates over conventional convoluted hose.
- **Vacuum resistant**
Usable with full vacuum dependent on specification and application details.
- **Construction**
Manufactured from FDA-approved PTFE.
- **Heat-resistant**
Usable at elevated temperatures, dependent on specification and application details.
- **Sizes:** 1/4" up to 1" nb.
- **Wide range of end fittings**
BSP, NPT, flanges, etc.

- **Exceptional flexibility**
Unique combination of smooth-bore and high flexibility.
- **Excellent chemical resistance**
Inert to all but a handful of uncommon industrial fluids.

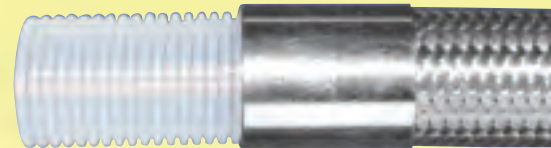

FS 28046

GUYSON

HOSE & COUPLINGS DIVISION

For capabilities and general technical data, see overleaf

KAPTECH

PTFE 4000 HYPERLINE FX FLEXIBLE SMOOTH BORE PTFE INDUSTRIAL HOSE ASSEMBLIES

Kaptech PTFE 4000 Hyperline FX smooth-bore convoluted PTFE hose offers a unique solution to the need for a smooth bore hose with the flexibility of a convoluted hose.

The PTFE 4000 Hyperline FX tube design incorporates integral external rib sections which support the tube against kinking, vacuum and pressure. Highly compressed web sections give a smooth inner surface with excellent flexibility.

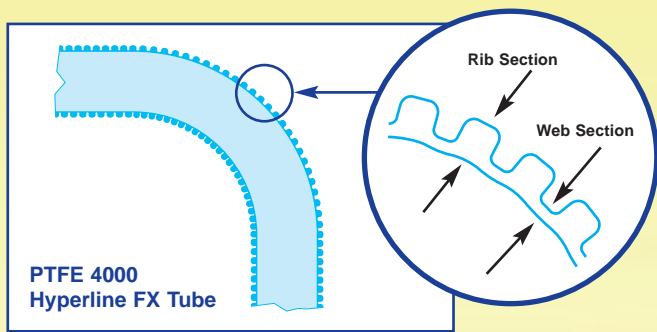

Anti-static: In addition to the standard translucent tube, Kaptech PTFE 4000 Hyperline FX is also available with an anti-static black PTFE tube (AS). This is designed for applications where fluids with a high electrical resistance are passed through the hose and allows the dissipation of static charge in accordance with international standards.



Tube Only: An unbraided tube-only option (TO) is also available for applications where a translucent, low pressure hose is required.

Other Kaptech PTFE hoses available include: PTFE 1000 smooth bore, PTFE 3000 convoluted (industrial applications) and PTFE 5000 Corroflon convoluted (process applications) and Bioflex smooth bore (process applications).

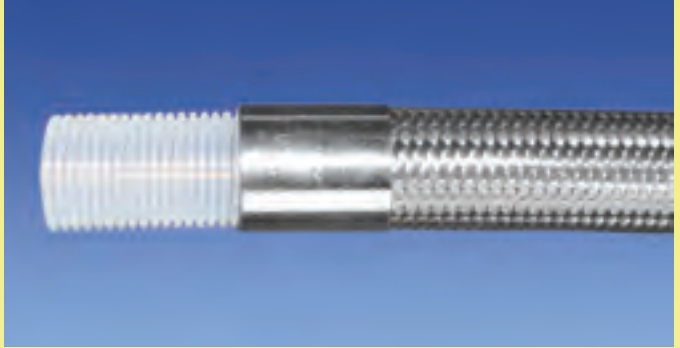

Braid Options:

Kaptech PTFE 4000 Hyperline FX hose is provided as standard with an external stainless steel braid.

As an option, it is also available with a black aramid fibre braid (AM) which provides a lightweight, durable braid with comfortable handling characteristics.

End Fittings.

Kaptech PTFE 4000 Hyperline FX hose assemblies can be fitted with most types of conventional end fittings. Standard types include BSP and NPT threaded fittings in zinc-plated mild steel and 316SS; swivel flanges in 304 and 316SS are also options.

Stainless Steel Braid			
Bore Size	Minimum Bend Radius	Maximum Working Pressure	Weight Per Metre
Inches	mm	bar	kg
1/4	19	88	0.092
3/8	25	80	0.160
1/2	38	60	0.225
3/4	63	42	0.383
1	75	40	0.540

Minimum bend radius and weight figures shown are for PTFE 4000 Hyperline FX with stainless steel braid.

Pressure Ratings: Pressure Ratings shown are for PTFE 4000 Hyperline FX with stainless steel braid at ambient temperature. For versions with other braids or tube only (TO) option, please consult Guyson Technical Sales Department.

Temperature Range: Usable at elevated temperatures dependent on specification and application details, please consult Guyson Technical Sales Department.



GUYSON INTERNATIONAL LIMITED HOSE & COUPLINGS DIVISION
Southview Business Park, Guiseley, Leeds LS20 9PR Tel: 01943 870044 Fax: 01943 870066
e-mail: leeds@guyson.co.uk web: www.guyson.co.uk



KAPTECH

CONVOLUTED PTFE INDUSTRIAL HOSE ASSEMBLIES

PTFE 3000 VISIFLON

- **Heat-resistant**
Usable up to 230°C, dependent on specification and application details.
- **Excellent steam resistance**
Longer service life than rubber steam hoses.
- **Vacuum resistant**
Usable with full vacuum dependent on specification and application details.
- **Lightweight**
Around 60% of the weight of a typical rubber hose.
- **Durable**
Tough outer braid protects against abrasion and damage.
- **Sizes:** 3/8" up to 2" nb.
- **Wide range of end fittings**
BSP, NPT, flanges, hygienic type, etc.

- **Exceptional flexibility**
Convoluted tube allows tight, kink-free bends and ease of handling.
- **Excellent chemical resistance**
Inert to all but a handful of uncommon chemicals.

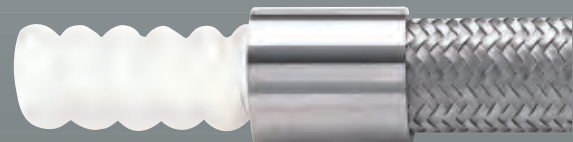

FS 28046

CUYSON

HOSE & COUPLINGS DIVISION

For capabilities and general technical data, see overleaf

KAPTECH

PTFE 3000 VISIFLON CONVOLUTED INDUSTRIAL HOSE ASSEMBLIES

Kaptech PTFE 3000 Visiflon convoluted PTFE hose offers a lightweight, flexible and durable solution for a wide range of arduous industrial applications.

Anti-static: In addition to the standard translucent tube, Kaptech PTFE 3000 Visiflon hose is also available with an anti-static black PTFE tube (AS). This is designed for applications where fluids with a high electrical resistance such as solvents and fuels are passed through the hose and allows the dissipation of any static charge in accordance with BS2050: 1978.

Tube Only: An unbraided tube-only option (TO) is also available for applications where a translucent, low-pressure hose is required.

Braid Options: Kaptech PTFE 3000 Visiflon PTFE hose is provided as standard with an external stainless steel braid. It is also available to special order, with a polymer braid (PB) manufactured from a polypropylene yarn which provides a lightweight braid with excellent chemical resistance and comfortable handling characteristics. Other specialist braids and covers are also available to special order.



Pressure ratings: Pressure Ratings shown are for PTFE 3000 Visiflon with stainless steel braid at ambient temperature. For versions with other braids or tube-only (TO) option, please consult Guyson Technical Department.

Temperature Range: Usable up to 230°C dependent on specification and application details, please consult Guyson Technical Department.



End Fittings.

Kaptech PTFE 3000 Visiflon hose assemblies can be fitted with all conventional types of end fittings.

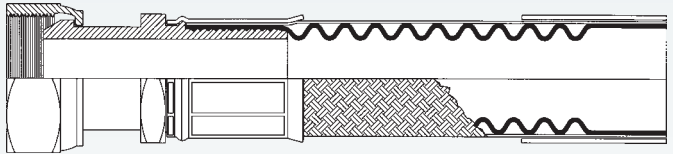

Standard types include BSP and NPT threaded fittings in zinc-plated mild steel and 316SS; swivel flanges in 304, 316SS and polypropylene are also options. A full range of hygienic type end fittings such as RJT, IDF and Tri-clamp are available. Cuffed ends suitable for customers to attach their own fittings are available to special order.

Although Kaptech PTFE 3000 Visiflon hose assemblies can be used for some light-duty process fluid applications, Kaptech PTFE 5000 (Corroflon) is usually preferred due to its thicker PTFE wall and helical wire reinforcement construction.

Stainless Steel Braided			
Bore Size	Minimum Bend Radius	Maximum Working Pressure	Weight Per Metre
Inches	mm	bar	kg
3/8	19	60	0.144
1/2	25	47	0.195
3/4	50	32	0.376
1	63	26	0.533
1 1/4	75	25	0.729
1 1/2	115	20	1.044
2	130	15	1.378

Pressure ratings shown are valid for Group 2 fluids only [per Pressure Equipment Directive 97/23/EC, Art.9 (2)]. Consult Guyson Technical Department for Group 1 (dangerous) fluids ratings.

Other Kaptech PTFE hoses available include: PTFE 1000 smooth bore, PTFE 4000 Hyperline FX smooth bore (industrial applications), PTFE 5000 Corroflon convoluted (process applications) and Bioflex smooth bore (process applications).



GUYSON INTERNATIONAL LIMITED HOSE & COUPLINGS DIVISION
 Southview Business Park, Guiseley, Leeds LS20 9PR Tel: 01943 870044 Fax: 01943 870066
 e-mail: leeds@guyson.co.uk web: www.guyson.co.uk



KAPTECH

STAINLESS STEEL HOSE ASSEMBLIES

- **Excellent corrosion resistance**
Stainless Steel hose construction throughout.
- **High Strength & Safety**
All-welded assembly gives total integrity of tube, braid and end fittings.
- **Wide pressure range**
From full vacuum up to 220 bar, dependent on exact specification.
- **Excellent flexibility**
Corrugated tube allows tight, kink-free bends and ease of handling.
- **Wide temperature range**
Between -200°C and +600°C, dependent on working pressure.
- **Fire and damage resistant**
Tough, all-metal construction.
- **Long service life**
Without the ageing deterioration of non-metal hoses.
- **Excellent steam resistance**
Longer service life than non-metal steam hoses.
- **Standard Sizes:**
1/4" up to 4" nb. Larger sizes are available on request.
- **Wide range of end fittings:**
BSP, NPT, flanges, hygienic type, specials, etc.

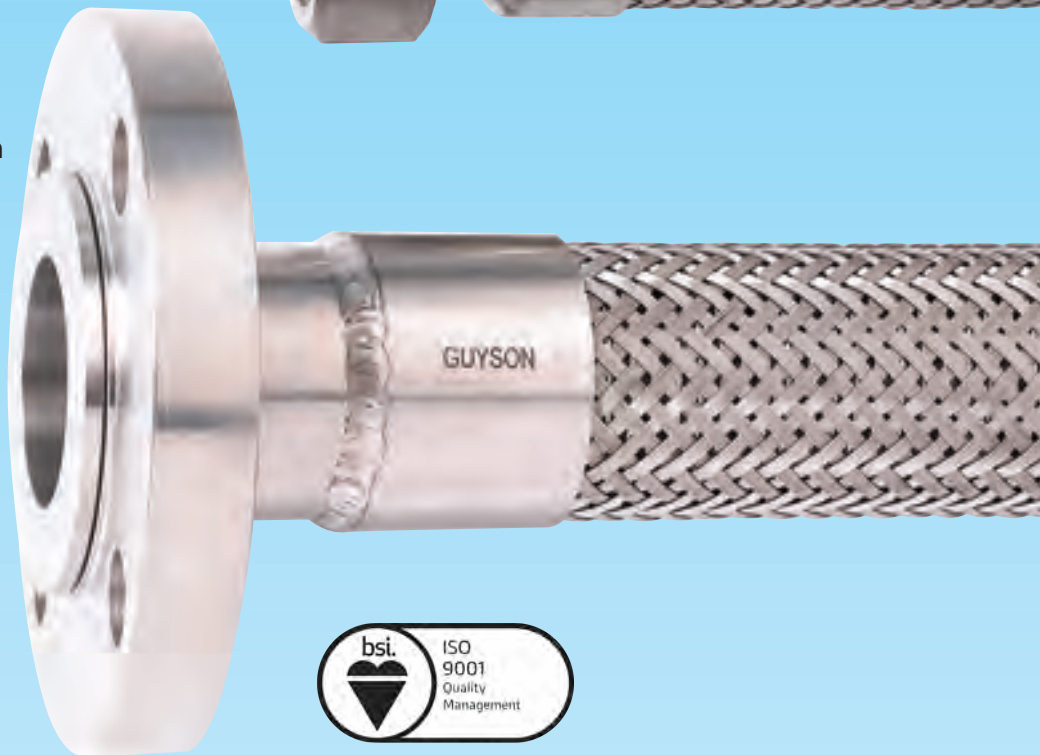
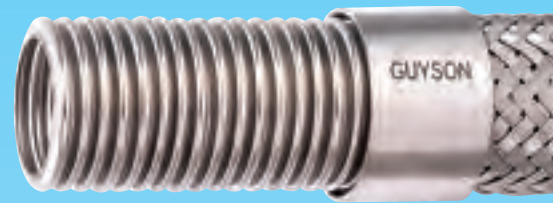

FS 28046

GUYSON

For capabilities and general technical data, see overleaf

KAPTECH

STAINLESS STEEL HOSE ASSEMBLIES

Construction: The Kaptech Stainless Steel flexible hose assemblies listed are manufactured from annularly-corrugated tube formed from butt-welded rigid tube, to BS6501 Part 1 type B flexibility; they also meet ISO 10380

class 1. Assemblies to type C flexibility are also freely available.

Single or double layers of wire braid are applied externally to the hose

and welded to the fittings at each end to give pressure holding capability and protection from abrasion. The extent of braiding, gauge and angle of lay is carefully calculated for optimum performance.

The stainless corrugated tube is available in 321 and 316 grade, with braid in 304 or 316; other materials such as bronze, Monel, etc., are also readily available.

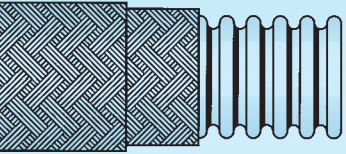

End Fittings:

Because Kaptech hose assemblies are individually made in our works they can have end fittings selected to suit customers' application

requirements from a wide range of standard and special configurations, including male & female BSP and NPT threads, fixed & swivel flanges to various specifications, hygienic fittings, tube ends, weld ends, quick-release couplings, etc.



Design & Installation: Kaptech Stainless Steel flexibles should be configured and installed in such a way that the minimum bend radius is not exceeded, the hose is not stretched, compressed nor twisted, and the external braid is not subject to wear nor damage.

The use of elbow ends can often help in achieving a satisfactory installation.



Optional Additional Features

Internal Liners - to protect tube against abrasion or high flow velocities.

External Casing - for protection against undue risk of overbending and external damage.

Rubber and Plastic Covers - to give anti-scuff and environmental protection, comfortable handling, and a wipe-clean surface.

External insulation - to maintain fluid temperature and protect operator.

Duplex Assemblies - hose-within-a-hose for heat-tracing or cooling.



KAPTECH Stainless Steel Hose Assemblies

NB	ISO 10380		Braid	O/D	Min Bend Radius		Maximum Pressure		Weight
	DN	PN			Static	Flexing	Working	Test	
1/4"	6	150	Single	11.4mm	25mm	110mm	167 bar	250 bar	0.16 kg/m
		150	Double	12.8			220	350	0.24
3/8"	10	100	Single	16.3	38	150	100	150	0.27
		150	Double	17.6			178	267	0.38
1/2"	12	63	Single	21	45	165	74	111	0.36
		100	Double	22.4			103	155	0.53
3/4"	20	63	Single	27.4	70	200	65	97	0.52
		63	Double	29			86	129	0.77
1"	25	50	Single	35.8	85	200	50	75	0.70
		63	Double	37.9			76	114	1.1
1 1/4"	32	25	Single	43.2	105	250	39	59	0.86
		50	Double	45.3			57	85	1.3
1 1/2"	40	25	Single	50	127	250	35	53	1.2
		50	Double	52.2			55	82	1.7
2"	50	25	Single	64.2	160	350	30	45	1.5
		40	Double	66.3			44	66	2.3
2 1/2"	65	25	Single	78.6	200	410	26	39	2.8
		40	Double	80.7			46	69	3.7
3"	80	20	Single	91.9	230	450	22	33	3.4
		40	Double	94.1			40	60	4.5
4"	100	16	Single	129	230	560	18	27	5.1
		25	Double	132			33	49	6.9

Intermediate and larger sizes available on request.

Pressure Ratings: The pressure ratings listed above are for Kaptech Stainless Steel hose assemblies at normal ambient temperatures.

The maximum working pressure gives a safety factor of 4:1 against the burst pressure. The maximum working pressures should be reduced according to the table opposite where higher temperatures are involved.

To prevent permanent damage to the hose the maximum test pressure must never be exceeded.

Flow: To avoid the risk of premature fatigue failure we suggest that flow rates of 45 m/sec (gas) and 22 m/sec (liquid) should not be exceeded for hose installed in a straight configuration; these values should be reduced by 50% for a 90° bend, 25% for a 45° bend, etc., proportionate to the angle of bend.

Note: All technical information shown above correct at time of print and may be subject to change without notice. For specific applications please consult Guyson Technical Department

Pressure ratings shown are valid for Group 2 fluids only [per Pressure Equipment Directive 97/23/EC, Art.9 (2)]. Consult Guyson Technical Department for Group 1 (dangerous) fluids ratings.

Temperature	321	316
-200 to +50°C	100%	100%
100	96	94
150	92	90
200	88	86
250	84	82
300	80	78
350	76	74
400	72	70
450	66	
500	60	
550	54	
600	44	

Pressure drop in Stainless Steel flexible hoses is approximately double that in plain steel pipe; this means that an increase in diameter of the hose of approximately 15% is sufficient to reduce the pressure drop to a similar value to that in plain steel pipe.

Whatever your hot water requirements, Dynafluid products give you the innovative answer. Dynafluid are the leading suppliers of steam and water mixing valves and washdown accessories in the UK.

Dynafluid 2000

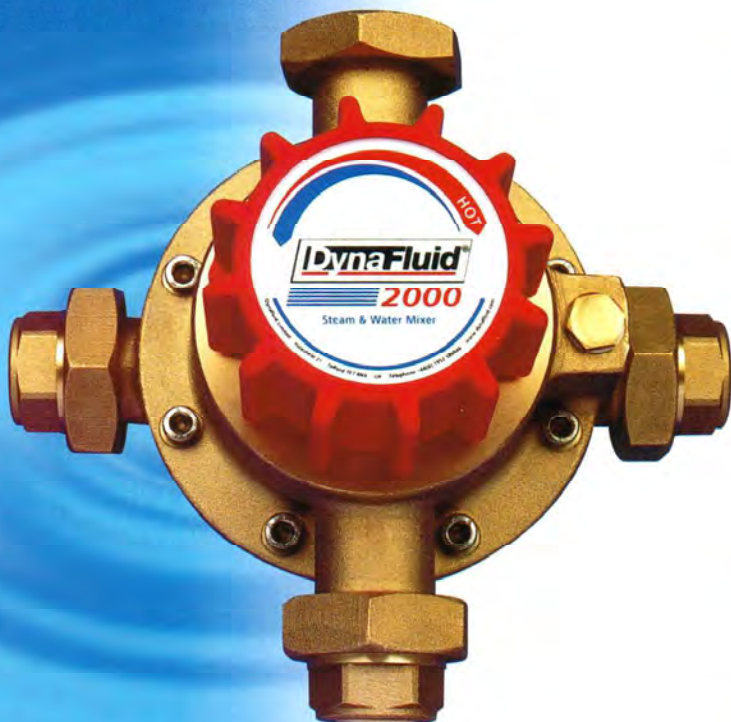

Steam and water mixing valves

- Outstanding economy - up to 80% cost savings
- Instantaneous hot water
- Available in four sizes from 1/2" to 1 1/2"
- Unique, proven over 40 years international experience
- Unrivalled operator safety - will not pass live steam
- Variety of finishes, inc. stainless steel for hygienic applications (3/4" only)
- Easy to service without removing from pipework - full spares availability

Dynafluid 3000



Hot and cold water mixing valve for washdown

- Cost effective solution for hot or warm water requirements
- Thermostatic control up to 70°C
- Safe - valve shuts down if cold water supply fails
- Accurate - controls temperature to within $\pm 2^{\circ}\text{C}$
- Available in two sizes - 1/2" & 3/4"
- Available in natural bronze or chrome finish



Dynafluid watergun range

- Trigger operated
- Automatic shut-off prevents wastage
- Variable from narrow jet to wide spray pattern
- Tough and durable, ideal for industrial environments
- Bronze body with brass internals as standard or full stainless steel version available for hygienic applications
- Black rubber cover as standard or white option available on request

Dynafluid washdown systems

- Complete washdown systems including valve, hose, hose reel and gun
- Pre-connected for easy installation



From a single component to a full washdown system - choose Dynafluid

GUYSON

Guyson International Limited
Hose & Couplings Division
Southview Business Park
Guiseley • Leeds LS20 9PR

Tel 01943 870044 • Fax 01943 870066
e-mail leeds@guyson.co.uk
www.guyson.co.uk



FS 28046



HANSEN



QUICK-CONNECTING
SELF-SEALING COUPLINGS

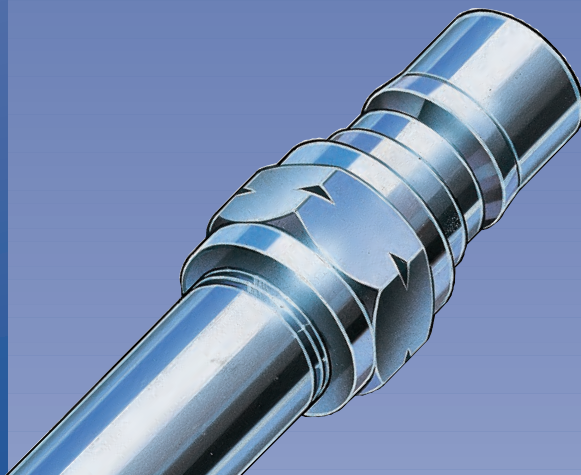

FS 28046



HANSEN HK SERIES

QUICK-CONNECTING

The connecting mechanism is of the ball-locking type, in which a ring of stainless steel balls in the socket half of the coupling locate in an accurately machined groove in the plug half; a spring-loaded external release sleeve on the socket controls the locking balls:



TO CONNECT

simply pull back the spring-loaded sleeve and push the socket on to the plug – the sleeve then snaps forward to lock the coupling securely.

TO DISCONNECT

just pull the sleeve back to unlock the coupling.

This quick-acting feature gives substantial advantages over conventional screwed connections:

- Tools are not needed and unskilled personnel can operate Hansen HK Couplings.
- Connection or disconnection is fast, needing no more than a second, and saves expensive labour costs and plant shut-down.
- Joints are guaranteed leak-free every time.
- Connections are foolproof – Hansen HK couplings cannot be wrongly or only partially connected, even in the most careless hands.
- The couplings can swivel through 360° when connected, thus increasing hose life by eliminating torsional stress, and facilitating installation.
- The locking mechanism is robust, reliable and maintenance-free.

SELF-SEALING

Spring-operated valves in both the socket and plug halves open automatically to allow full flow of liquid or gas on connection, and give automatic, positive shut-off on disconnection, eliminating all chances of fluid escape due to error.

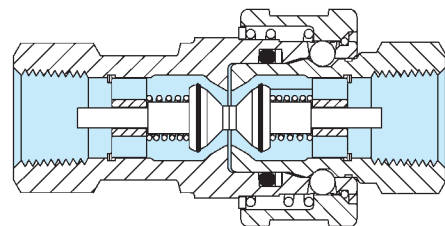
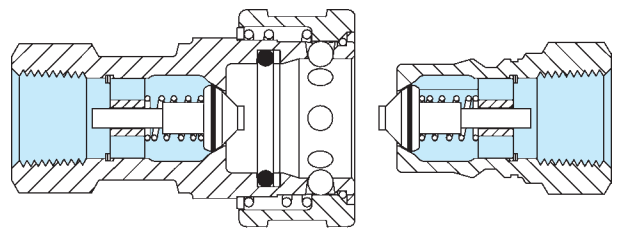

HK Couplings are so designed that, when the coupling is being connected, the seal is made before the valves open to allow fluid to flow. On disconnection the valves close to seal off both ends of the line before the main coupling seal is broken.

- Shut-off against escape of fluid is automatic, it is not subject to error or forgetfulness by the operator and there is no 'half-way' point.
- Loss or spillage of fluid on connection and disconnection is negligible.
- The cost, bulk and complication of separate manually-operated valves can often be avoided.
- Cleanliness in the working area is increased and risk of contamination of the fluid being carried is reduced.
- Increased safety in handling inflammable, corrosive or other dangerous fluids is assured by eliminating the possibility of open pipe ends.

HANSEN COUPLINGS IN ACTION

Hansen HK series couplings give flexibility in system design or plant lay-out by allowing fluid line connections to be made in a variety of different configurations, according to system



requirements. They can be used for connecting a flexible hose to a fixed pipe, vessel, cylinder, etc., connecting a hose between two fixed points, plugging-in an instrument (e.g. a pressure gauge) to test points, or connecting two hoses together. Where one hose may need to be connected to several outlets, or several hoses to one outlet, the hoses or outlets not in use remain automatically sealed.

HANSEN QUALITY

Hansen couplings have a world-wide reputation for quality of design and manufacture. Hansen's renowned quality standards – tight tolerances on mating parts,

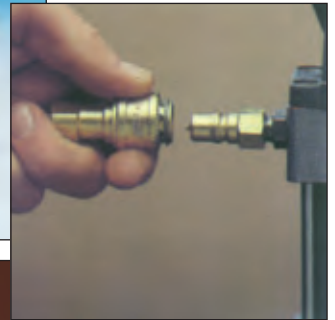

micro-finished sealing surfaces, and precision elastomer seals – means that Hansen couplings give long, dependable service, even in the most difficult industrial applications. Although many copy Hansen designs, few duplicate the high standards of materials specification and manufacturing quality which Hansen steadfastly maintains.

WIDE CHOICE OF MATERIALS

Hansen HK couplings are available in an extensive choice of material specifications giving an unrivalled range of fluid compatibility.

STEEL, BRASS, STAINLESS STEEL

are the standard body metals available – in each case machined from solid bar. Steel parts are hardened in critical areas and selected couplings use special alloy steels with differential through-hardening to give maximum service life under tough conditions of pressure and handling.

ALTERNATIVE SEALS

extend the versatility of Hansen couplings to cover most industrial liquids and gases; the list below shows some of the many diverse fluids successfully conveyed. The availability of the pick of seal technology in Hansen couplings means reliable, leak-free sealing can often be obtained under the most difficult application conditions.

WIDE RANGE OF FLUIDS HANDLED

Hydraulic Fluids	Ammonia	Methanol
Compressed air	CO ²	Methyl ethyl ketone
Water	Brake Fluid	Nitrogen
Lubricants	Butane	Oxygen
Vacuum	Caustic solutions	Propane
Solvents	Beer	Skydrol
Steam	Diesel fuel	Soft Drinks
Refrigerants	Ethanol	Natural gas
Acetone	Ethylene glycol	Toluene
Acetylene	Fuel oils	Trichlorethylene
Acids	Helium	Whisky
Alkalies	Jet Fuel	

Check exact specifications with Guyson Technical Department

HOW TO SELECT

METALS

All Hansen HK series couplings are readily available in steel, brass and stainless steel versions as standard. Irrespective of the basic metal of construction, critical parts such as locking balls, valve, springs, etc, are of stainless steel.

Pressure ratings (see following pages) may influence choice of body material.

Pressure ratings shown are valid for Group 2 fluids only [per Pressure Equipment Directive 97/23/EC, Art.9 (2)].

Consult Guyson Technical Department for Group 1 (dangerous) fluids ratings.

SEALS

Hansen HK couplings incorporate high-grade elastomeric seals. The nitrile seal material supplied as standard gives excellent resistance to oil, air, water and many other liquids and gases. In addition, various optional seal compounds such as Viton, EPDM, Kalrez, PTFE etc. are readily available as alternatives where arduous operating conditions such as elevated temperatures apply. This choice of seal materials, in conjunction with the alternative metals available, allows Hansen HK couplings to give service in an unrivalled range of applications (see examples opposite).

SIZES

Hansen HK couplings are available in ten basic sizes with end connections ranging from 1/8" to 3", covering most commonly-used hose bore sizes. Because of smooth flow-path design and generous proportions, a Hansen HK coupling have an appropriate size of end connection to fit a system's hose or pipe will give ample flow of liquid or gas in most applications. If flow rates are unusual or critical, the pressure drop figures can be checked as indicated on the back cover or by consulting Guyson Technical Department.

HOSE ASSEMBLIES

For most applications, Hansen HK couplings can also be supplied as part of a tested, ready-to-use flexible hose assembly. Please contact our sales department to discuss your specific requirements.

PART NUMBERS

SERIES	SOCKET	PLUG	THREAD
1HK	1H11	1K11	1/8" NPTF
2HK	2H16-BS	2K16-BS	1/4" BSP
	2H16	2K16	1/4" NPTF
3HK	3H21-BS	3K21-BS	3/8" BSP
	3H21	3K21	3/8" NPTF
4HKP	4HP26-BS	4KP26-BS	1/2" BSP
	4HP26	4KP26	1/2" NPTF
6HKP	6HP31-BS	6KP31-BS	3/4" BSP
	6HP31	6KP31	3/4" NPTF
8HKP	8HP36-BS	8KP36-BS	1" BSP
	8HP36	8KP36	1" NPTF
10HK	10H41-BS	10K41-BS	1 1/4" BSP
	10H41	10K41	1 1/4" NPTF
12HK	12H41-BS	12K41-BS	1 1/4" BSP
	12H41	12K41	1 1/4" NPTF
	12H46-BS	12K46-BS	1 1/2" BSP
20HK	20H51-BS	20K51-BS	2" BSP
	20H51	20K51	2" NPTF
	20H56-BS	20K56-BS	2 1/2" BSP
	20H56	20K56	2 1/2" NPTF
24HK	20H61-BS	20K61-BS	3" BSP
	20H61	20K61	3" NPTF
24HK	24H61-SL	24K61	3" NPTF

ONE-WAY SHUT-OFF:

Any socket or plug can be supplied in a version which does not self-seal on disconnection, allowing draining or venting, yet which still actuates the valve in the other coupling half.

To order, add the suffix '-VAA' to the listed part number, e.g. 1H11-VAA

PRESSURE RATINGS

SERIES	BAR
1HK	275
2HK	345
3HK	255
4HKP	345
6HKP	275
8HKP	275
10HK	118
12HK	152
20HK	104
24HK	120

Pressure ratings shown are valid for Group 2 fluids only [per Pressure Equipment Directive 97/23/EC, Art.9 (2)]. Consult Guyson Technical Department for Group 1 (dangerous) fluid ratings.

Service pressure ratings provide maximum safe pressures in bar for liquid (e.g hydraulic) and gas applications. Longer service life may be obtained at lower system pressures.

The pressure ratings above are valid for couplings in both the connected and disconnected states. Pressures at which the couplings can be manually connected are considerably lower - consult Guyson Technical Department for information if required.

For dimensions, flow capacities and dust caps see back cover.

STEEL COUPLINGS



Hansen HK Series couplings in carbon steel have a corrosion-resistant zinc-plated finish. They are generally suitable for hydraulic oils, compressed air, vacuum, lubricants, refrigerants, solvents, etc.

BRASS COUPLINGS



Hansen HK Series couplings in brass are commonly preferred for water, steam, liquid and gaseous fuels, etc., where complete freedom from rusting is required.

PART NUMBERS

SERIES	SOCKET	PLUG	THREAD
1HK	B1H11	B1K11	1/8" NPTF
2HK	B2H16-BS B2H16	B2K16-BS B2K16	1/4" BSP 1/4" NPTF
3HK	B3H21-BS B3H21	B3K21-BS B3K21	3/8" BSP 3/8" NPTF
4HKP	B4HP26-BS B4HP26	B4KP26-BS B4KP26	1/2" BSP 1/2" NPTF
6HKP	B6HP31-BS B6HP31	B6KP31-BS B6KP31	3/4" BSP 3/4" NPTF
8HKP	B8HP36-BS B8HP36	B8KP36-BS B8KP36	1" BSP 1" NPTF
10HK	B10H41	B10K41	1 1/4" NPTF
12HK	B12H41-BS B12H41	B12K41-BS B12K41	1 1/4" BSP 1 1/4" NPTF
12HK	B12H46-BS B12H46	B12K46-BS B12K46	1 1/2" BSP 1 1/2" NPTF
20HK	B20H51-BS B20H51	B20K51-BS B20K51	2" BSP 2" NPTF
20HK	B20H56-BS B20H56	B20K56-BS B20K56	2 1/2" BSP 2 1/2" NPTF
20HK	B20H61-BS B20H61	B20K61-BS B20K61	3" BSP 3" NPTF

ONE-WAY SHUT-OFF:

Any socket or plug can be supplied in a version which does not self-seal on disconnection, allowing draining or venting, yet which still actuates the valve in the other coupling half.

To order, add the suffix '-VAA' to the listed part number, e.g. B1H11-VAA

PRESSURE RATINGS

SERIES	BAR
1HK	207
2HK	186
3HK	152
4HKP	155
6HKP	138
8HKP	103
10HK	83
12HK	104
20HK	49

Pressure ratings shown are valid for Group 2 fluids only [per Pressure Equipment Directive 97/23/EC, Art.9 (2)]. Consult Guyson Technical Department for Group 1 (dangerous) fluid ratings.

Service pressure ratings provide maximum safe pressures in bar for liquid (e.g hydraulic) and gas applications. Longer service life may be obtained at lower system pressures.

The pressure ratings above are valid for couplings in both the connected and disconnected states. Pressures at which the couplings can be manually connected are considerably lower - consult Guyson Technical Department for information if required.

For dimensions, flow capacities and dust caps see back cover.

PART NUMBERS

SERIES	TYPE 303		TYPE 316		THREAD
	SOCKET	PLUG	SOCKET	PLUG	
1HK	LL1H11-BS	LL1K11-BS	-	-	1/8" BSP
	LL1H11	LL1K11	ML1H11	ML1K11	1/8" NPTF
2HK	LL2H16-BS	LL2K16-BS	ML2H16-BS	ML2K16-BS	1/4" BSP
	LL2H16	LL2K16	ML2H16	ML2K16	1/4" NPTF
3HK	LL3H21-BS	LL3K21-BS	ML3H21-BS	ML3K21-BS	3/8" BSP
	LL3H21	LL3K21	ML3H21	ML3K21	3/8" NPTF
4HKP	LL4HP26-BS	LL4KP26-BS	ML4HP26-BS	ML4KP26-BS	1/2" BSP
	LL4HP26	LL4KP26	ML4HP26	ML4KP26	1/2" NPTF
6HKP	LL6HP31-BS	LL6KP31-BS	ML6HP31-BS	ML6KP31-BS	3/4" BSP
	LL6HP31	LL6KP31	ML6HP31	ML6KP31	3/4" NPTF
8HKP	LL8HP36-BS	LL8KP36-BS	ML8HP36-BS	ML8KP36-BS	1" BSP
	LL8HP36	LL8KP36	ML8HP36	ML8KP36	1" NPTF
10HK	LL10H41	LL10K41	-	-	1.1/4" NPTF
12HK	LL12H41-BS	LL12K41-BS	-	-	1.1/4" BSP
	LL12H41	LL12K41	-	-	1.1/4" NPTF
12HK	LL12H46-BS	LL12K46-BS	ML12H46-BS	ML12K46-BS	1.1/2" BSP
	LL12H46	LL12K46	-	-	1.1/2" NPTF
20HK	LL20H51-BS	LL20K51-BS	-	-	2" BSP
	LL20H51	LL20K51	-	-	2" NPTF
20HK	LL20H56-BS	LL20K56-BS	-	-	2.1/2" BSP
	LL20H56	LL20K56	-	-	2.1/2" NPTF
20HK	LL20H61-BS	LL20K61-BS	-	-	3" BSP
	LL20H61	LL20K61	-	-	3" NPTF

ONE-WAY SHUT-OFF:

Any socket or plug can be supplied in a version which does not self-seal on disconnection, allowing draining or venting, yet which still actuates the valve in the other coupling half.

To order, add the suffix '-VAA' to the listed part number, e.g. LL1H11-BS-VAA

PRESSURE RATINGS

SERIES	BAR
1HK	344
2HK	255
3HK	255
4HKP	293
6HKP	242
8HKP	173
10HK	118
12HK	152
20HK	104

Pressure ratings shown are valid for Group 2 fluids only [per Pressure Equipment Directive 97/23/EC, Art.9 (2)]. Consult Guyson Technical Department for Group 1 (dangerous) fluid ratings.

Service pressure ratings provide maximum safe pressures in bar for liquid (e.g hydraulic) and gas applications. Longer service life may be obtained at lower system pressures.

The pressure ratings above are valid for couplings in both the connected and disconnected states. Pressures at which the couplings can be manually connected are considerably lower - consult Guyson Technical Department for information if required.

For dimensions, flow capacities and dust caps see back cover.

STAINLESS STEEL COUPLINGS



Hansen HK Series couplings in stainless steel are chosen to handle many corrosive liquids and gases, fluids where high purity must be maintained, high vacuum, etc. They are also useful for non-aggressive fluids in corrosive environments.

APPROXIMATE DIMENSIONS

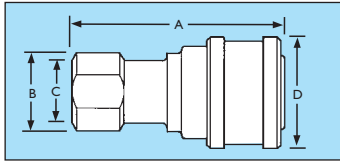

SOCKET	A	B	C thrd	D
1H11	49mm	18	1/8"	26
2H16	58	23	1/4"	30
3H21	65	26	3/8"	37
4HP26	75	33	1/2"	48
6HP31	89	40	3/4"	57
8HP36	105	51	1"	67

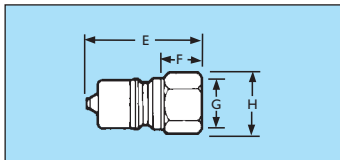

PLUG	E	F	G thrd	H
1K11	32mm	11	1/8"	17
2K16	39	14	1/4"	23
3K21	45	15	3/8"	26
4KP26	52	19	1/2"	33
6KP31	60	18	3/4"	39
8KP36	73	25	1"	48

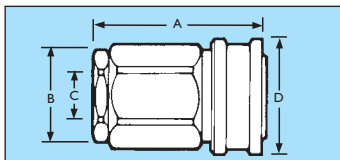

SOCKET	A	B	C thrd	D
10H41	115mm	68	1.1/4"	70
12H41	122	77	1.1/4"	83
12H46	122	77	1.1/2"	83
20H51	140	110	2"	105
20H56	156	110	2.1/2"	105
20H61	178	110	3"	105
24H61SL	180	133	3"	138

Approx length connected = A + F

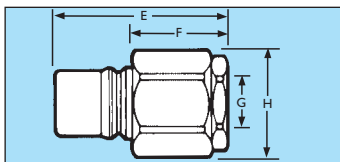

PLUG	E	F	G thrd	H
10K41	108mm	58	1.1/4"	68
12K41	121	68	1.1/4"	77
12K46	121	68	1.1/2"	77
20K51	140	75	2"	110
20K56	155	90	2.1/2"	110
20K61	177	112	3"	110
24K61	180	101	3"	133

Dimensions given apply to sockets and plugs irrespective of body material.

FLOW CAPACITIES

The flow co-efficients (Cv) in the list below enable the approximate pressure drop (Δp) in bar across the connected coupling to be calculated as follows:

$$\Delta p = \left(\frac{\text{litres/min}}{C_v \times 3.8} \right)^2 \times 0.069 \text{ where water is the flow medium}$$

Example: Find approx. pressure drop across the 3HK coupling at a flow rate of 15 litres/min.

$$\Delta p = \left(\frac{15}{1.9 \times 3.8} \right)^2 \times 0.069 = 0.3 \text{ bar approx}$$

1HK	0.5
2HK	1.1
3HK	1.9
4HKP	3.2
6HKP	7.2

8HKP	10.3
10HK	16.9
12HK	24.0
20HK	50.0
24HK	106.0

For other liquids and for gases, consult Guyson Technical Department.

DUST CAPS

Dust caps are available where protection is necessary against excessive flying grit or dust. The Socket Dust Cap is easily applied by pulling back the Socket Sleeve and inserting the Dust Cap. The Plug Dust Cap covers the entire machined surface of the Plug. It is applied and held in place by friction on the locking portion of the Plug. Metal dust caps are supplied with a chain and attachment ring. Plastic dust caps have an integral plastic strap and attachment loop.

SERIES	SOCKET DUST CAP		PLUG DUST CAP	
	METAL	PLASTIC	METAL	PLASTIC
1-HK	SDC-1HK	P-SDC-1HK	PDC-1HK	P-PDC-1HK
2-HK	SDC-2HK	P-SDC-2HK	PDC-2HK	P-PDC-2HK
3-HK	SDC-3HK	P-SDC-3HK	PDC-3HK	P-PDC-3HK
4-HK	SDC-4HK	P-SDC-4HK	PDC-4HK	P-PDC-4HK
6-HK	SDC-6HK	P-SDC-6HK	PDC-6HK	P-PDC-6HK
8-HK	SDC-8HK	P-SDC-8HK	PDC-8HK	P-PDC-8HK
10-HK	-	P-SDC-8HK	-	P-PDC-8HK
12-HK	SDC-12HK	-	PDC-12HK	-
20-HK	SDC-20HK	-	PDC-20HK	-

GUYSON SERVICE

Guyson Technical Department offers immediate advice and assistance in selection of suitable Hansen couplings, fittings, hose assemblies, adaptors, etc., for any application, based on more than 90 years of specialist experience. Our Sales Office provides fast information on prices and deliveries and same-day despatch of your urgent requirements.



GUYSON INTERNATIONAL LIMITED HOSE AND COUPLINGS DIVISION

Southview Business Park, Guiseley, Leeds LS20 9PR

Tel: 01943 870044 Fax: 01943 870066

Email: leeds@guyson.co.uk Web: www.guyson.co.uk



FS 28046